

Çapraz Kanal Frezeler

Milling - Disc Milling Cutters

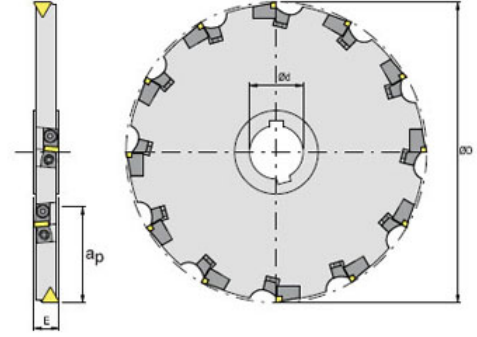

Kod Code	Stok Stock	Ölçüler Dimension						Uç Tipi Insert Type	Baskı Pabucu Clamp	Baskı Vidası Clamp Screw	Sağ Altlık Anvil Right	Sol Altlık Anvil Left	Uç Vidası Insert Screw	Anahtar Wrench
		ØD	Ød	E	ap	Z								
TKF	125 18 16	○	125	40	18	30	8	TP... 1603PPN	FB 12	FR 650	FK 16 P-R	FK 16 P-L	M4 x 15	Ta4
	125 20 16	○	125	40	20	30	8							
	160 18 16	○	160	40	18	45	10							
	160 20 16	○	160	40	20	45	10							
	200 20 16	○	200	50	20	60	12							
	200 24 16	○	200	50	24	60	12							
	250 20 16	○	250	50	20	60	16							
	250 24 16	○	250	50	24	60	16							
	315 24 16	○	315	60	24	70	20							
	400 24 16	○	400	60	24	80	24							



R : Sağ / Right L : Sol / Left
● Stoktan / Stock

● 2 Hafta / in two weeks

Sipariş Örneği / Ordering Sample : TKF 125 20 16
○ Stokta yok / Non stock item

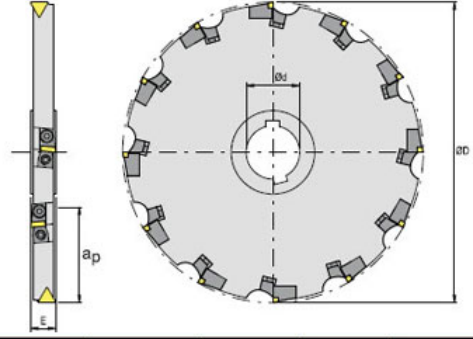

Kod Code	Stok Stock	Ölçüler Dimensions				Z	Uç Tipi Insert Type	Baskı Pabucu Clamp	Baskı Vidası Clamp Screw	Sağ Altlık Anvil Right	Sol Altlık Anvil Left	Uç Vidası Insert Screw	Anahtar Wrench	
		ØD	Ød	E	ap									
TKF	80 10 11	○	80	27	10	15	6	TP... 1103PPN	331.2.851	FR 649	R331 2 832	L331 2 833	M3 x 12	Ta3
	80 12 11	○	80	27	12	15	6							
	100 10 11	○	100	32	10	24	8							
	100 12 11	○	100	32	12	24	8							
	125 10 11	○	125	40	10	30	10							
	125 12 11	○	125	40	12	30	10							
	160 10 11	○	160	40	10	45	12							
	160 12 11	○	160	40	12	45	12							
	160 14 11	○	160	40	14	45	12							
	200 10 11	○	200	50	10	60	16							
	200 12 11	○	200	50	12	60	16							
	200 14 11	○	200	50	14	60	16							

Kanal Frezeler, Yüzey Frezeler

Milling - Disc Milling Cutters

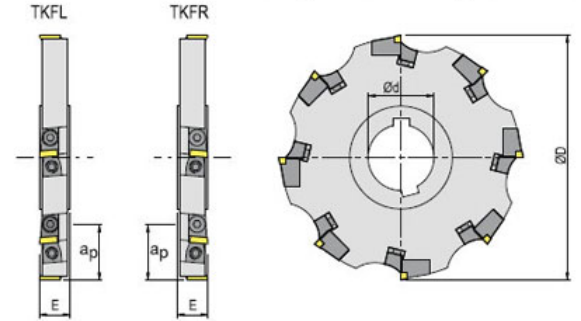

Kod Code	Stok Stock		Ölçüler Dimensions				Z	Uç Tipi Insert Type	Baskı Pabucu Clamp	Baskı Vidası Clamp Screw	Sağ Altlık Anvil Right	Sol Altlık Anvil Left	Uç Vidası Insert Screw	Anahtar Wrench
	R	L	ØD	Ød	E	ap								
TKFR/L	125 18 16	○ ○	125	40	18	30	8	TP... 1603PPN	FB 12	FR 650	FK 16 P-R	FK 16 P-L	M4 x 15	Ta4
	125 20 16	○ ○	125	40	20	30	8							
	160 18 16	○ ○	160	40	18	45	10							
	160 20 16	○ ○	160	40	20	45	10							
	200 20 16	○ ○	200	50	20	60	12							
	200 24 16	○ ○	200	50	24	60	12							
	250 20 16	○ ○	250	50	20	60	16							
	250 24 16	○ ○	250	50	24	60	16							
	315 24 16	○ ○	315	60	24	70	20							
	400 24 16	○ ○	400	60	24	80	24							

Çapraz Kanal Frezeler

Milling - Disc Milling Cutters

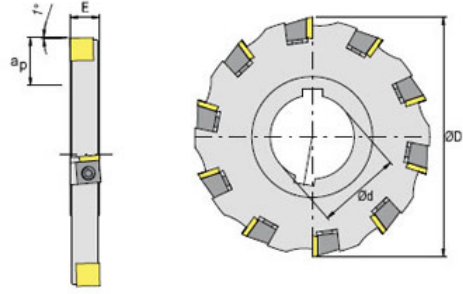

Kod Code	Stok Stock	Ölçüler Dimensions				Z	Uç Tipi Insert Type	Baskı Pabucu Clamp	Baskı Vidası Clamp Screw	Anahtar Wrench	
		ØD	Ød	E	a _p						
S2	100 14 12	○	100	32	14	24	10	SPUN 1203..	S2 12 R/L	FR 650	Ta4
	100 16 12	○	100	32	16	24	10				
	125 14 12	○	125	40	14	30	12				
	125 16 12	○	125	40	16	30	12				
	160 14 12	○	160	40	14	45	16				
	160 16 12	○	160	40	16	45	16				
	200 14 12	○	200	50	14	60	18				
	200 16 12	○	200	50	16	60	18				
	250 14 12	○	250	50	14	60	24				
	250 16 12	○	250	50	16	60	24				

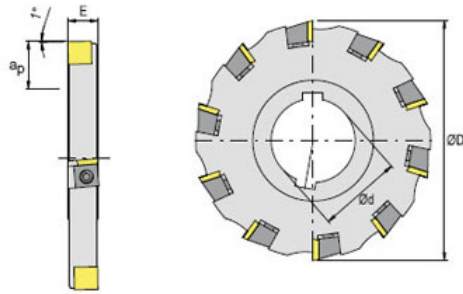

Kod Code	Stok Stock	Ölçüler Dimensions				Z	Uç Tipi Insert Type	Baskı Pabucu Clamp	Baskı Vidası Clamp Screw	Anahtar Wrench	
		ØD	Ød	E	a _p						
TDK	80 10 09	○	80	27	10	18	6	SPUN 0903..	TDB 09 R/L	FR 648	Ta3
	100 10 09	○	100	32	10	24	10				
	100 12 09	○	100	32	12	24	10				
	125 10 09	○	125	40	10	30	12				
	125 12 09	○	125	40	12	30	12				
	160 10 09	○	160	40	10	45	18				
	160 12 09	○	160	40	12	45	18				
	200 10 09	○	200	50	10	60	22				
	200 12 09	○	200	50	12	60	22				

Sipariş Örneği / Ordering Example :S2 100 14 12

● Stoktan / Stock

⌚ 2 Hafta / in two weeks

○ Stokta yok / Non stock item

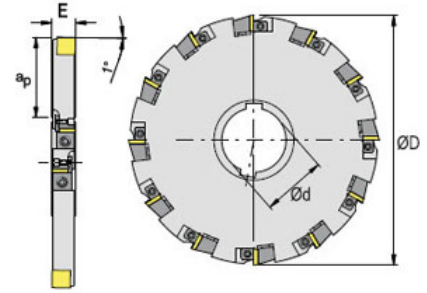

Kod Code	Stok Stock	Ölçüler Dimensions				Z	Uç Tipi Insert Type	Baskı Pabucu Clamp	Baskı Vidası Clamp Screw	Anahtar Wrench
		ØD	Ød	E	a _p					
TSK	100 16 12	○	100	32	16	24	SPUN 1203..	S2 12 R/L	FR 650	Ta4
	100 18 12	○	100	32	18	24				
	125 16 12	○	125	40	16	30				
	125 18 12	○	125	40	18	30				
	160 16 12	○	160	40	16	45				
	160 18 12	○	160	40	18	45				
	200 16 12	○	200	50	16	60				
	200 18 12	○	200	50	18	60				
	250 16 12	○	250	50	16	60				
	250 18 12	○	250	50	18	60				

Dar Kanal Frezeler

Milling - Disc Milling Cutters

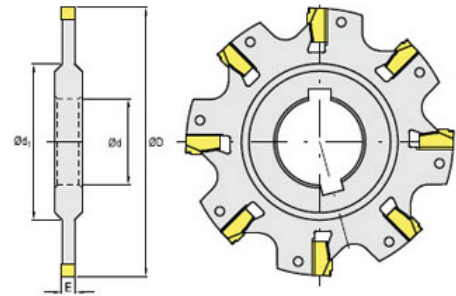

Kod Code	Stok Stock	Ölçüler Dimensions				Z	Uç Tipi Insert Type
		ØD	Ød	E	Ød ₁		
330 20	080 030 230	○	80	27	3	45	N 151 2 300
	100 030 230	○	100	32	3	58	
	125 030 230	○	125	40	3	62	
	160 030 230	○	160	40	3	62	
	080 040 240	○	80	27	4	45	N 151 2 400
	100 040 240	○	100	32	4	58	
	125 040 240	○	125	40	4	62	
	160 040 240	○	160	40	4	62	
	080 050 250	○	80	27	5	45	N 151 2 500
	100 050 250	○	100	32	5	58	
	125 050 250	○	125	40	5	62	
	160 050 250	○	160	40	5	62	
	080 060 260	○	80	27	6	45	N 151 2 600
	100 060 260	○	100	32	6	58	
	125 060 260	○	125	40	6	62	
	160 060 260	○	160	40	6	62	

Dar Kanal Frezeler

Milling - Disc Milling Cutters

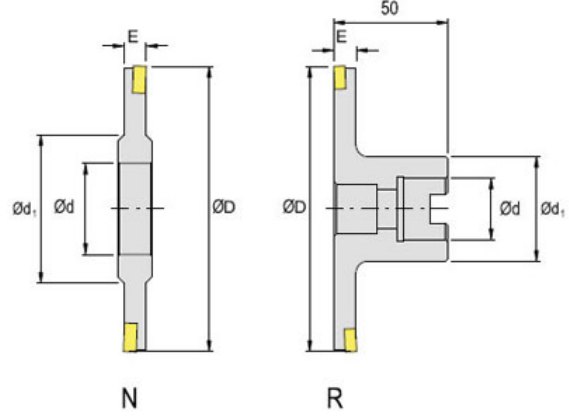

Kod Code	Stok Stock	Ölçüler Dimensions				Z	Uç Tipi Insert Type	Uç Vidası Insert Screw	Torx Anahtar Torx Wrench
		ØD	Ød	E	Ød ₁				
TK 80 93 SLN12 N06	○	80	27	6-7	44	8	LNEW 1235 / LNEW 1240	7815102	T15 IP
80 93 SLN12 N08	○	80	27	8-9	44	8	LNEW 1240 / LNEW 1245	7815102	
100 93 SLN12 N06	○	100	32	6-7	52	10	LNEW 1235 / LNEW 1240	7815102	
100 93 SLN12 N08	○	100	32	8-9	52	10	LNEW 1240 / LNEW 1245	7815102	
125 93 SLN12 N06	○	125	40	6-7	63	12	LNEW 1235 / LNEW 1240	7815102	
125 93 SLN12 N08	○	125	40	8-9	63	12	LNEW 1240 / LNEW 1245	7815102	
125 93 SLN12 N10	○	125	40	10-11	63	12	LNEW 1245 / LNEW 1250	7815102	
160 93 SLN12 N06	○	160	40	6-7	63	16	LNEW 1235 / LNEW 1240	7815102	
160 93 SLN12 N08	○	160	40	8-9	63	16	LNEW 1240 / LNEW 1245	7815102	
160 93 SLN12 N10	○	160	40	10-11	63	16	LNEW 1245 / LNEW 1250	7815102	
160 93 SLN12 N12	○	160	40	12-13	63	16	LNEW 1245 / LNEW 1250	7815102	
200 93 SLN12 N06	○	200	50	6-7	75	18	LNEW 1235 / LNEW 1240	7815102	
200 93 SLN12 N08	○	200	50	8-9	75	18	LNEW 1240 / LNEW 1245	7815102	
200 93 SLN12 N10	○	200	50	10-11	75	18	LNEW 1245 / LNEW 1250	7815102	
200 93 SLN12 N12	○	200	50	12-13	75	18	LNEW 1245 / LNEW 1250	7815102	
80 93 SLN12 R06	○	80	22	6-7	42	8	LNEW 1235 / LNEW 1240	7815102	
80 93 SLN12 R08	○	80	22	8-9	42	8	LNEW 1240 / LNEW 1245	7815102	
100 93 SLN12 R06	○	100	27	6-7	50	10	LNEW 1235 / LNEW 1240	7815102	
100 93 SLN12 R08	○	100	27	8-9	50	10	LNEW 1240 / LNEW 1245	7815102	
125 93 SLN12 R06	○	125	40	6-7	70	12	LNEW 1235 / LNEW 1240	7815102	
125 93 SLN12 R08	○	125	40	8-9	70	12	LNEW 1240 / LNEW 1245	7815102	
125 93 SLN12 R10	○	125	40	10-11	70	12	LNEW 1245 / LNEW 1250	7815102	
160 93 SLN12 R06	○	160	40	6-7	70	16	LNEW 1235 / LNEW 1240	7815102	
160 93 SLN12 R08	○	160	40	8-9	70	16	LNEW 1240 / LNEW 1245	7815102	
160 93 SLN12 R10	○	160	40	10-11	70	16	LNEW 1245 / LNEW 1250	7815102	

Sipariş Örneği / Ordering Example :TK 160 93 SLN12 N08

● Stoktan / Stock

● 2 Hafta / in two weeks

○ Stokta yok / Non stock item

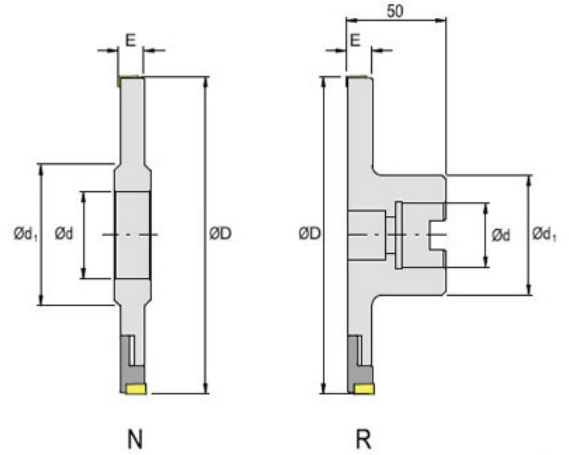

Kod Code	Stok Stock	Ölçüler Dimensions				Z	Uç Tipi Insert Type	Uç Vidası Insert Screw	Sağ Kartuş Cartridge Right	Sol Kartuş Cartridge Left	Dayama Parçası Limit Piece	Torx Anahtar Torx Wrench	
		ØD	Ød	E	Ød ₁								
TK	125 93 SCN10 N14	○	125	40	14-18	60	8	CNHW(T) 1005	7883203	93 SCN10 KFA R	93 SCN10 KFA L	93 SCN10 AP	T08 IP
	125 93 SCN12 N18	○	125	40	18-22	60	8	CNHW(T) 1205	7883209	93 SCN12 KFA R	93 SCN12 KFA L	93 SCN12 AP	T15 IP
	160 93 SCN10 N14	○	160	40	14-18	63	10	CNHW(T) 1005	7883203	93 SCN10 KFA R	93 SCN10 KFA L	93 SCN10 AP	T08 IP
	160 93 SCN12 N18	○	160	40	18-22	70	10	CNHW(T) 1205	7883209	93 SCN12 KFA R	93 SCN12 KFA L	93 SCN12 AP	T15 IP
	200 93 SCN10 N14	○	200	50	14-18	75	12	CNHW(T) 1005	7883203	93 SCN10 KFA R	93 SCN10 KFA L	93 SCN10 AP	T08 IP
	200 93 SCN12 N18	○	200	50	18-22	75	12	CNHW(T) 1205	7883209	93 SCN12 KFA R	93 SCN12 KFA L	93 SCN12 AP	T15 IP
	250 93 SCN10 N14	○	250	50	14-18	75	16	CNHW(T) 1005	7883203	93 SCN10 KFA R	93 SCN10 KFA L	93 SCN10 AP	T08 IP
	250 93 SCN12 N18	○	250	50	18-22	75	16	CNHW(T) 1205	7883209	93 SCN12 KFA R	93 SCN12 KFA L	93 SCN12 AP	T15 IP
	125 93 SCN10 R14	○	125	40	14-18	60	8	CNHW(T) 1005	7883203	93 SCN10 KFA R	93 SCN10 KFA L	93 SCN10 AP	T08 IP
	125 93 SCN12 R18	○	125	40	18-22	60	8	CNHW(T) 1205	7883209	93 SCN12 KFA R	93 SCN12 KFA L	93 SCN12 AP	T15 IP
	160 93 SCN10 R14	○	160	40	14-18	63	10	CNHW(T) 1005	7883203	93 SCN10 KFA R	93 SCN10 KFA L	93 SCN10 AP	T08 IP
	160 93 SCN12 R18	○	160	40	18-22	70	10	CNHW(T) 1205	7883209	93 SCN12 KFA R	93 SCN12 KFA L	93 SCN12 AP	T15 IP
	200 93 SCN10 R14	○	200	50	14-18	75	12	CNHW(T) 1005	7883203	93 SCN10 KFA R	93 SCN10 KFA L	93 SCN10 AP	T08 IP
	200 93 SCN12 R18	○	200	50	18-22	75	12	CNHW(T) 1205	7883209	93 SCN12 KFA R	93 SCN12 KFA L	93 SCN12 AP	T15 IP
	250 93 SCN10 R14	○	250	50	14-18	75	16	CNHW(T) 1005	7883203	93 SCN10 KFA R	93 SCN10 KFA L	93 SCN10 AP	T08 IP
	250 93 SCN12 R18	○	250	50	18-22	75	16	CNHW(T) 1205	7883209	93 SCN12 KFA R	93 SCN12 KFA L	93 SCN12 AP	T15 IP

UYGULAMA TAVSİYELERİ

93 SCN DISC MİLL Tipinde dar kanal frezeler, özel kartuş konstrüksiyonları ile 4 mm'ye kadar ayar imkanına olanak sağlar.

- 1- Standart formunda, montajlı kartuşlar ve ara parçalar ile birlikte kanal genişliği (E) 14 mm'dir.
- 2- Eğer bir taraftaki kartuşun altındaki ayar parçası kaldırılırsa genişlik (E) 16 mm'ye arttırılır.
- 3- Maksimum kanal genişliğini elde etmek için freze, ayar ara parçaları olmadan monte edilmiştir. Bu konumda kanal genişliği (E) 18 mm'dir.

APPLICATION

Disc mill type 93 SCN, provides the possibility of adjusting up to 4 mm by special cartridge.

- 1- In standard form, cartridge and fastening parts provides width of (E) 14 mm.
- 2- If the adjustment of cartridge in one side are cancelled, width is enlarged to (E) 16 mm.
- 3- Maximum width can be achieved without adjustment parts. In that way the width becomes (E) 18 mm.

